

A Member of the Constructor Group



Storage solutions since 1947

# Product Catalogue

Storage solutions tailored to your needs



STORAGE SYSTEMS

# Optimise your storage solution



## About us

Dexion is part of Constructor Group, a leading European manufacturer and distributor of high quality storage products. Whatever the storage requirement, Dexion can make a genuine contribution to improving your business by providing premium storage products and services.



## Our valued distribution partners

For over 50 years, Dexion has meticulously worked to forge a nationwide network of premium distributors – all of whom are fully trained and highly experienced on both product and brand. Each distributor can provide advice on warehouse design and storage solutions and, once installed, they will happily offer an aftercare service of safety inspections, repairs, replacements, system extensions or extra safety accessories. Dexion's trusted network of valued distributors are seen as part of the Dexion family and as such can offer core benefits such as:

- Responsive, local contacts
- Warehouse layout design
- Dexion rack design
- Safe load assessments
- Safety rack inspections
- Replacement parts
- Repairs and alterations
- Safety accessories
- Additional related products

## Benefits of being a Dexion customer

- ✓ Dedicated local service
- ✓ Technical support
- ✓ Aftersales support
- ✓ Popular items in stock

FOR MORE INFORMATION CONTACT YOUR LOCAL  
DEXION DISTRIBUTOR

# Index

	page ▼
Slotted Angle	4
Speedframe	5
NEW Economy Shelving Systems 100 and 175	6
Premium Economy Shelving Systems Galvanised / Painted 80	7
Premium Economy Shelving - Chipboard 150	8
NEW Economy Shelving System 375	8
NEW Economy Shelving System 480	9
Longspan Shelving	10
Maxi Bins, Hooks & Louvered Panels	11
HI280 Shelving System	12
HI280 Medium Span	13
HI280 Mobile Shelving	14
HI280 Multi-Tier Shelving	15
HI280 Ship Shelving	16
HI280 Tyre Racking	17
HI280 Accessories	18-19
P90 Pallet Racking	20
P90 Wide Aisle Pallet Racking	21
P90 Narrow Aisle & High Bay Racking	22
P90 MOVO - Mobile Pallet Racking	23

	page ▼
P90 Multi-Tier	24
P90 Drive-In Racking	25
P90 Pallet Shuttle	26
P90 Pallet Flow Racking	27
P90 Push-Back Racking	28
P90 Carton Flow Racking	29
P90 Accessories - Pull-Out Units	30
P90 Accessories - Dividers, Vertical Dividers etc.	31
P90 Accessories - shelf options	32
P90 Rack Protection	33-34
NEW Galvanised Light Duty Cantilever Racking	35
Heavy Duty Cantilever Racking	36
Mezzanine Floor	37
Partitioning Systems	38
Storage Machines	39
Rack Inspections	40



# Slotted Angle

- ✓ The original Dexion Shelving System, sold globally for over 60 years
- ✓ **Extremely flexible and versatile system**
- ✓ Simple and easy to construct
- ✓ Slotted Angle can be cut to size to suit your application
- ✓ Ideal for benches, shelving, access platforms, jigs and test rigs

Used worldwide for benches, shelving, safety screens, access platforms, fire barriers, security cages, jigs, test rigs & 1001 other applications.

The slot pattern means that all four angles can be used together in one installation and the slots are designed to provide the maximum number of nut and bolt positions.

When used with shelves listed below each shelf has of a load capacity of **180kg**

Available in painted or pre-galvanised finish



Angle Type	Min Qty	Overall Size W x D x Gauge x L mm	Finish
140	5	36 x 36 x 1.75 x 3048	Pre-galvanised Painted



Type	Min Qty	Description / Finish
Fixings	50	M8 Nuts BZP
	50	M8 x 16 Set Screw BZP



Angle Type	Min Qty	Overall Size W x D x Gauge x L mm	Finish
160	5	40 x 40 x 2.00 x 3048	Pre-galvanised Painted



Type	Min Qty	Description / Finish
8mm Corner Plates	20	Pre-galvanised
	20	Painted



Angle Type	Min Qty	Overall Size W x D x Gauge x L mm	Finish
225	5	62 x 41 x 2.00 x 3048	Pre-galvanised Painted



Type	Min Qty	Description / Finish
Base Plates	Single	Single
	Single	Double



Angle Type	Min Qty	Overall Size W x D x Gauge x L mm	Finish
260	5	66 x 45 x 2.50 x 3048	Painted



Type	Length (mm)	Depth (mm)	Paint	Galv
Shelf	914	305	Y	Y
	914	381	Y	Y
	914	457	Y	Y
	914	610	Y	Y
	991	305	Y	Y
	991	381	Y	Y
	991	457	Y	Y
	991	610	Y	Y

It is recommended to use Corner Plates on 140 or 260 angle.

Other sizes are available upon request.

Shelves are capable of storing up to 180kg per shelf

# Speedframe

- ✓ The Dexion framework system with a **high quality finish**
- ✓ Cut the tube to the required length, connect the joints and it's ready to use
- ✓ Full design and cutting service available
- ✓ Easy to assemble and reassemble
- ✓ Ideal for benches, trolleys or display stands

The Dexion Speedframe construction system allows you to design and build your own structure. The tube can be simply cut to length, insert the joints and assemble as required. With a few additional accessories, Speedframe can quickly be built into something new. A bench, a desk frame, a trolley or even a display stand.

## Easy to build in 3 simple steps

### Step 1

Make a sketch of the item you need and cut the tube to the required length



### Step 2

Fit the corner joints and any accessories



### Step 3

Complete your design



Tube Pack (3.05m lengths)



Black Tube Insert



2 Way Joint



3 Way Joint



3 Way Corner Joint



4 Way Flat Joint



4 Way Joint



5 Way Joint



6 Way Joint



Single Shelf Support



Double Shelf Support



Plastic Shelf Spacer



Chrome Foot Cover



Anchor Plate



Removable Shelf Support



Plastic End Cap



Adjustable Foot



Single Glazing Strip



Castor Wheel

FOR MORE INFORMATION CONTACT YOUR LOCAL DEXION DISTRIBUTOR

## ECONOMY 100 Shelving *economy range*

Chipboard shelves, galvanised frame

- ✓ Maximum load capacity per shelf is 100kg uniformly distributed load
- ✓ Designed for storerooms and garages
- ✓ Boltless mounting system allows fast and easy assembly
- ✓ Shelf positions are adjustable
- ✓ Competitively priced



Dimensions of the assembled shelving system:  
1500mm x 700mm x 350mm  
(H x W x D)

Galvanised  
finish



100kg  
per shelf

## ECONOMY 175 Shelving *economy range*

Chipboard shelves, galvanised frame

- ✓ Maximum load capacity per shelf is 175kg uniformly distributed load
- ✓ Designed for storerooms and garages
- ✓ Boltless mounting system allows fast and easy assembly
- ✓ Shelf positions are adjustable
- ✓ Competitively priced



Dimensions of the assembled shelving system:  
1800mm x 900mm x 450mm  
(H x W x D)

Galvanised  
finish



175kg  
per shelf



# Premium Economy 80 Shelving

economy range

Painted shelves, painted frame

- ✓ Maximum load capacity per shelf is 80kg uniformly distributed load
- ✓ Designed for storerooms, garages or offices
- ✓ Painted finish offers a high quality appearance
- ✓ Boltless mounting system allows fast and easy assembly
- ✓ Shelf positions are adjustable



Dimensions of the assembled shelving system:  
2000mm x 1000mm x 450mm  
(H x W x D)

Painted shelves



80kg  
per shelf

# Premium Economy 80 Shelving

economy range

Galvanised shelves, painted frame

- ✓ Maximum load capacity per shelf is 80kg uniformly distributed load
- ✓ Designed for storerooms, garages or offices
- ✓ Painted finish offers a high quality appearance
- ✓ Boltless mounting system allows fast and easy assembly
- ✓ Shelf positions are adjustable



Dimensions of the assembled shelving system:  
2000mm x 1000mm x 450mm  
(H x W x D)

Galvanised shelves



80kg  
per shelf

## Premium Economy 150 Shelving

economy range

Chipboard shelves, painted frame

- ✓ Maximum load capacity per shelf is 150kg uniformly distributed load
- ✓ Designed for storerooms, garages or offices
- ✓ Chipboard shelves
- ✓ Boltless mounting system allows fast and easy assembly
- ✓ Shelf positions are adjustable



Dimensions of the assembled shelving system:  
2000mm x 1000mm x 450mm  
(H x W x D)

Chipboard shelves

150kg  
per shelf



## ECONOMY 375 Shelving - Galvanised finish

economy range

Chipboard shelves, galvanised frame

- ✓ Maximum load capacity per shelf is 375kg uniformly distributed load
- ✓ Designed for storerooms, workshops and garages
- ✓ Boltless mounting system allows fast and easy assembly
- ✓ Shelf positions are adjustable
- ✓ High load capacity ideal for heavier storage



Dimensions of the assembled shelving system:  
1800mm x 900mm x 500mm  
(H x W x D)

Chipboard shelves

375kg  
per shelf







# Longspan Shelving

- ✓ Wide span shelves up to 3000mm
- ✓ Bolted frame for strength and reliability
- ✓ Quick and easy to assemble
- ✓ Ideal for storage of big and bulky items
- ✓ Designed for storerooms, archive storage and workshops

Dexion Longspan offers you virtually unlimited opportunities to expand your storage capacity, giving you higher density storage and greater flexibility whether you are storing boxes, cartons, tubes or wires. Long uninterrupted shelves of up to 3000mm make Longspan ideal for a wide range of big and bulky items and for archive storage.



Easy as 1-2-3!

The fastest way to build rigid, tough high capacity shelves for archives and awkward loads.



- Position a pair of frames. Connect the beams to the frame.
- Click the remaining beams into place.
- Drop in the steel or chipboard shelves.

# Maxi Bins, Hooks & Louvered Panels

- ✓ Versatile bin storage and small parts handling system
- ✓ Maxi Bins produced from high grade polypropylene
- ✓ Stack, use freestanding or hang on a louvered panel
- ✓ Label holders and dividers available
- ✓ Hooks and spigots also available for louvered panels

The comprehensive range of Maxi Bins provides a versatile, modern storage and handling solution for all kinds of items. Maxi Bins are extremely durable, resistant to both oil and water, and are designed to stand up to constant use in demanding working environments.



## Maxi Bins

no.	Overall Size W x D x H (mm)	Load Capacity	Volume (ltrs.)
1	100 x 125 x 60	2.3 kg	0.40
2	100 x 175 x 85	4.5 kg	0.75
3	135 x 225 x 125	9 kg	2.10
4	185 x 300 x 145	13 kg	4.25
5	185 x 450 x 145	13 kg	7.20
6	370 x 300 x 145	18 kg	10.00
7	410 x 450 x 215	27 kg	21.00

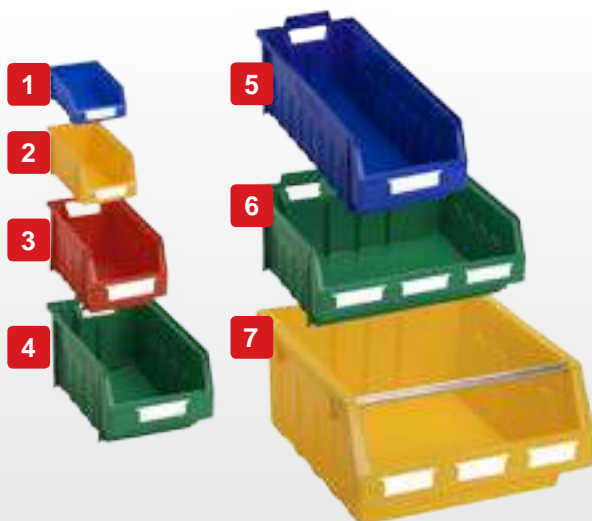

## Louvered Panels

no.	Width	Height
a	457mm	475mm
b	457mm	904mm
c	457mm	1372mm
d	457mm	1892mm

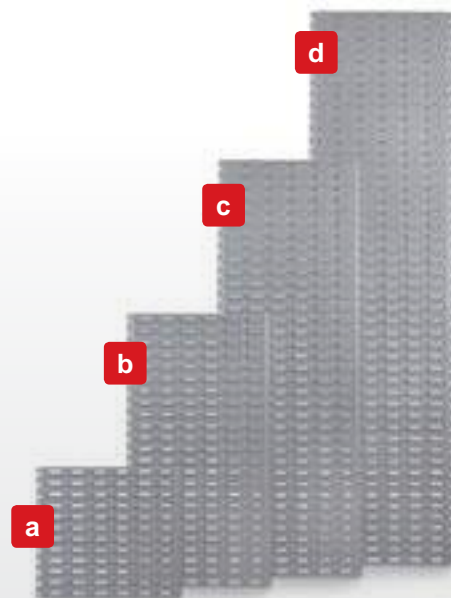

Hooks & spigots are also available

FOR MORE INFORMATION CONTACT YOUR LOCAL  
DEXION DISTRIBUTOR



# HI280 Industrial Shelving

- ✓ Sturdy and durable storage solution
- ✓ Suitable for runs of multiple bays
- ✓ Easy to install and available in a range of sizes
- ✓ Wide range of accessories available
- ✓ Designed for the smallest garage right up to the largest warehouse

## Dimensions

Depth: 300, 400, 450, 500, 600, 800, 1000 mm

Length: 900, 1000, 1290, 1500, 1750, 2000, 2250, 2500 mm

Height: 1000, 1600, 2100, 2300, 2500, 3000, 4600 mm  
(and in increments of 1000mm up to 9900mm)



Our HI280 system is ideal for storage and distribution companies. It offers immediate yet secure access to all items being stored. Increasing productivity and flexibility, which are key factors in today's competitive market. As your business develops, this system will grow with you to ensure you can always meet rapidly changing market needs.



FOR MORE INFORMATION CONTACT YOUR LOCAL  
DEXION DISTRIBUTOR

# HI280

## Medium Span

- ✓ Stores bulky or unwieldy goods efficiently
- ✓ Picking from both sides available
- ✓ Easy to integrate with other HI280 Shelving
- ✓ Spans up to 2500mm
- ✓ Accessories are available



**Maximise  
storage**



### Shelves

High quality metal panel shelves are provided as standard. A range of alternative shelving options are available including chipboard, perforated or mesh shelves or sloping shelves.

### Dimensions

HI280 Medium Span frames are available in heights from 1 to 8 metres

Shelf depths are: 300 / 400 / 500 / 600 / 800 / 1000 mm.

Shelf lengths are: 1 / 1.6 / 2.1 / 2.3 / 2.5 / 3.0m

### Loading

Dexion's HI280 was designed and is manufactured in Germany to high, quality assured standards. All products in this range have been rigidly tested in our in-house testing facility.

# Mobile HI280 Shelving System

- ✓ Utilisation of floor space, doubling capacity
- ✓ Secure storage with the ability to lock the entire unit
- ✓ Smooth and quiet movement of shelving
- ✓ Increased storage capacity in a smaller area
- ✓ Ideal for warehouses or workshops where space is limited



Save space

This shelving system provides a security-conscious storage facility. The mobile units can be locked and access given only through an electronic code or key.

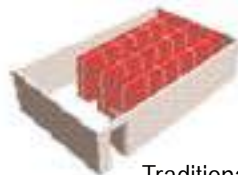

Traditional storage layout



Double capacity in same space

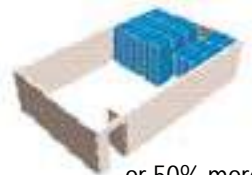

or 50% more floor space



 **Contact us for details**



# HI280 Multi-Tier Shelving

- ✓ Good space utilisation by using multiple levels
- ✓ Increased picking rates
- ✓ Reduce travel time between picks
- ✓ Increased storage capacity
- ✓ Sprinklers and lighting easily incorporated into system

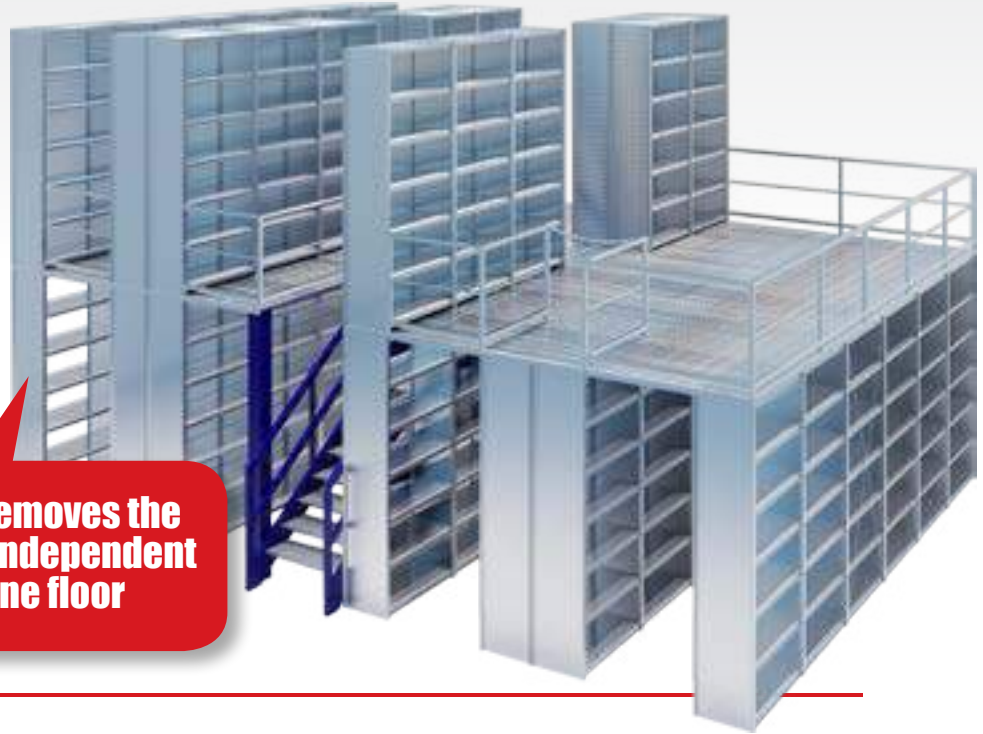

**Multi-Tier removes the need for an independent mezzanine floor**

The shelving works as a support for the mezzanine floor. The heavy duty construction of the uprights are designed to carry the loads from the floors above. Sprinkler systems and lighting can easily be incorporated into the structure.



**Contact us for details**



FOR MORE INFORMATION CONTACT YOUR LOCAL  
DEXION DISTRIBUTOR

## HI280 Ship Shelving

- ✓ Designed for storage of products at sea
- ✓ Designed to prevent goods falling out
- ✓ Shelves can be subdivided to increase storage options
- ✓ Quality design and robust finish, ideal for harsh environments
- ✓ Locking of the system optional for sensitive items

**Painted finish**  
to doors



HI280 Ship Shelving utilises the basic components of standard HI280 shelving, while adding additional elements make it suitable for storing of goods at sea.



# HI280 Tyre Racking

- ✓ Ideal for storage of winter, summer or all season tyres
- ✓ Designed to avoid point loads and flat spots on tyres
- ✓ Multiple tyre storage options available
- ✓ Spans up to 2000mm and offers good storage capacity
- ✓ System made from high quality pre-galvanised steel



Static racking

More and more car owners are having two sets of tyres, one set for summer and another for winter.



Mobile racking

HI280 Tyre Racking can be mounted on mobile bases to provide even denser storage of tyres, while providing access to each individual tyre.

FOR MORE INFORMATION CONTACT YOUR LOCAL  
DEXION DISTRIBUTOR



# HI280 Accessories

Various accessory parts make individual adaption for stored goods or for difficult spaces easier. There is always a solution for you. Below is a selection of accessories available.

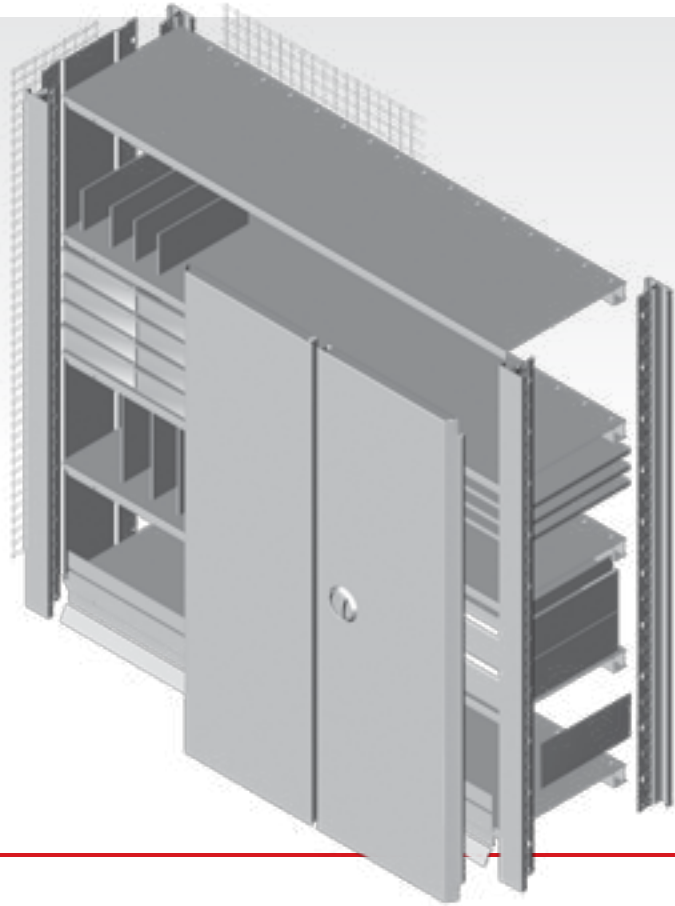

**Tool Panels** - Ideal for storing smaller items, available in a number of sizes.



See **Maxi Bins** on page 11

**Plastic Trays and Bins** - Ideal for storing smaller items, available in a number of sizes.



**Shelf Drawers** - Ideal for storing smaller items. The nest of shelf drawers sits directly on a shelf.



**Draw dividers** available

**Pull Out Drawers** - Supported on expansion slides, ideal for lean production areas.



**Full Height Dividers** - Used to create compartments between shelves allowing segregated storage of items.



**Bin Front** - Fitted to the front of the shelf to prevent goods from falling off.



**Part Height Dividers** - Used to subdivide products, where full height separation is not required.



**Base Plinth** - Placed at the bottom of the shelving unit. Prevents items from going under the shelving.



**Tube Rail** - Used as a storage rail for hanging garments.



**Lockable Doors** - Full and part height lockable doors offer secure storage.



**Bay Divider** - Used to segregate long goods when stored vertically. Allows fast and direct access.



**Tyre Bracket** - Allows tyres to rest on larger surface avoiding point loads and flat spots.



**Sign Holder** - Clipped to the upright providing easier aisle identification.



**Perforated Shelf** - Ideal for storing liquids, car batteries. Use in conjunction with a drip tray to collect spills.



**Sloping Shelf** - Two panels form a complete shelf. Used to display products and make picking easier.



**U Support** - Used to support vertically stored long goods, e.g. timber, plastic pipes.



**'S' & Twisted Hooks** - Used with a hanging rail. Ideal for exhausts, fan belts or any item that can be hung.



**Exhaust Support** - Front to back bar suspended between two shelf beams. Used in conjunction with 'S' or twisted hooks.



**Vertical Loop Divider** - Ideal for separating wide items stored vertically e.g. windscreen or doors.

## P90 Pallet Racking System

- ✓ Available in a range of various lengths
- ✓ Structures can be created in excess of 30 metres high
- ✓ 16 beam lengths with 30 different section sizes available
- ✓ Galvanised steel
- ✓ Also available with a painted finish
- ✓ Suitable for all pallet types including Euro, CHEP, disposable etc.
- ✓ Bespoke items manufactured to suit



### Quality Assured

Our products meet all relevant design codes including FEM, EN and SEMA. Our highly trained technical engineers ensure that storage solutions meet the required legislation and exceed our own internal high standards.

We are holders of  
ISO 9001, ISO 14001  
and ISO 18001





# P90 Wide Aisle Pallet Racking

## - the classic solution

- ✓ Large range of sizes and lengths available
- ✓ Wide aisles allow the use of standard counter-balance fork lift trucks
- ✓ Suitable for all pallet types
- ✓ Available in galvanised finish to optimise warehouse lighting
- ✓ Bespoke items manufactured to suit



FOR MORE INFORMATION CONTACT YOUR LOCAL  
DEXION DISTRIBUTOR

## P90 Narrow Aisle and High Bay Racking

- for faster order picking

- ✓ Narrow Aisles allow for better floor utilisation
- ✓ Used in conjunction with special forklift trucks
- ✓ Suitable for all pallet types
- ✓ Available in galvanised finish to optimise warehouse lighting
- ✓ Pallet handling and picking on all levels with combination truck





# P90 Movo

## - Mobile Pallet Racking

- ✓ High density storage saves on floor space
- ✓ Full access to all pallets via electronically controlled racking
- ✓ Meets FIFO requirements
- ✓ Suitable for cold stores
- ✓ Can be integrated with WMS



The electronically controlled heavy duty Mobile Pallet Racking system runs on embedded rails and can carry bay loads of up to 24 tonnes at heights of up to 12 metres, with runs up to 90m possible.

When individual aisles open, state-of-the-art sensor technology and variable control options ensure ease of operation and absolute safety.

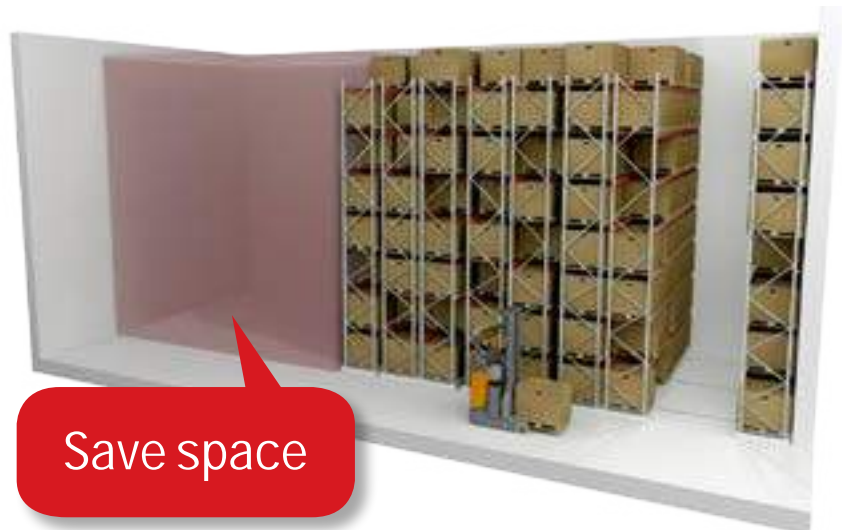

FOR MORE INFORMATION CONTACT YOUR LOCAL DEXION DISTRIBUTOR



## P90 Multi-Tier

### - utilising the full height of your warehouse

- ✓ Utilises the full height of the building
- ✓ **Optimises floor space**
- ✓ Allows order picking on multiple levels
- ✓ Can combine pallet storage and small goods storage
- ✓ Supports FIFO and LIFO

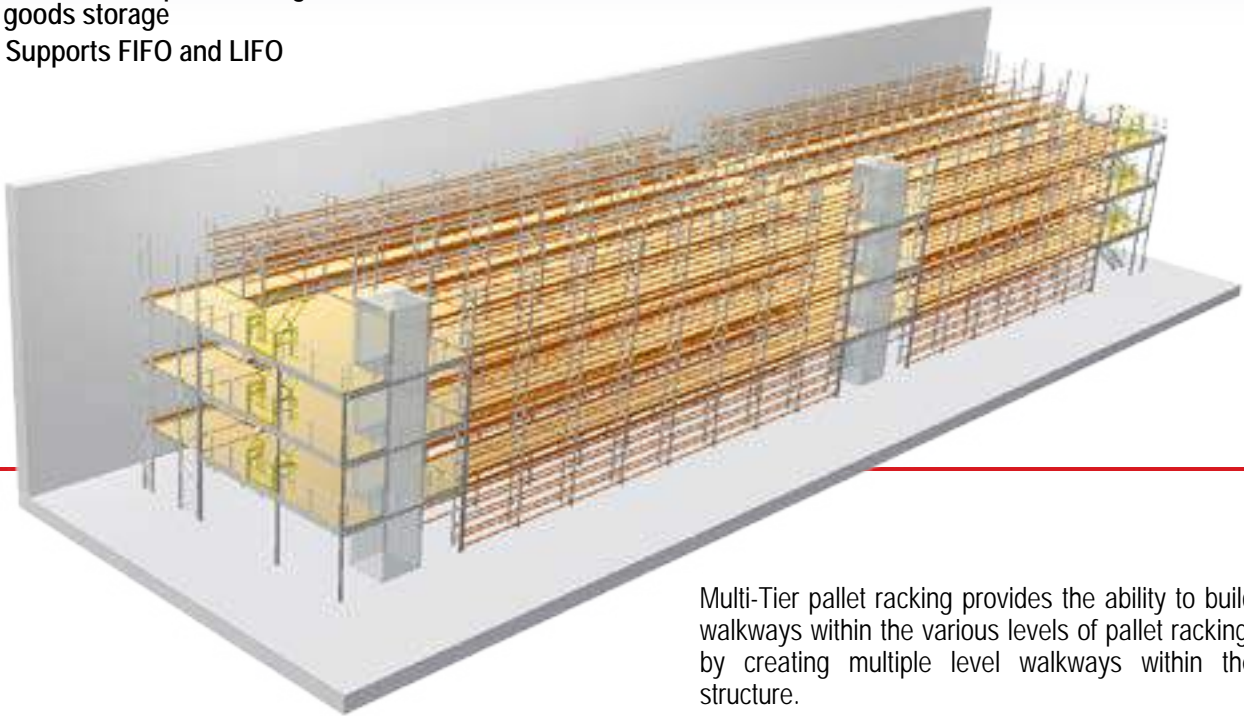

Multi-Tier pallet racking provides the ability to build walkways within the various levels of pallet racking, by creating multiple level walkways within the structure.

This type of structure can be more economical and offers a better utilisation of space than other mezzanine floor arrangements. Ideal for cartons, boxes and garment storage.



# P90 Drive-In Racking

- compact storage solution

- ✓ Perfect for storing large quantities of similar sized items
- ✓ Often used in a cold store environment
- ✓ Suitable for FILO operations
- ✓ Can be operated with a reach truck or counter-balanced fork lift truck
- ✓ Ideal for bulk storage



Drive-In Racking is the perfect solution when storing large quantities of similar products. This high density solution is often used in cold store environments.



FOR MORE INFORMATION CONTACT YOUR LOCAL  
DEXION DISTRIBUTOR



# P90 Pallet Shuttle System

## - cost effective automation

- ✓ Semi-automated warehouse system
- ✓ Pallets placed into and retrieved from the system via automated shuttle
- ✓ Can be used for both LIFO and FIFO operations
- ✓ Can dramatically reduce the number of forklift trucks required
- ✓ Suitable for use in both ambient and frozen environments



Pallet Shuttle System combines the advantages of Drive-In Racking with a semi-automated platform which manages the movements of pallets, offering better flexibility and faster handling.



FOR MORE INFORMATION CONTACT YOUR LOCAL  
DEXION DISTRIBUTOR



# P90 Pallet Flow Racking

- controlled roller movement

- ✓ Pallet racking used in conjunction with rollers
- ✓ Ideal for FIFO operations
- ✓ Pallet speed can be controlled by brakes within the system
- ✓ Can be operated by reach truck or counter-balance forklift truck
- ✓ Allows for high density storage of pallets



Pallet Flow is a compact storage system where pallets are transferred automatically from the entrance to the exit of the racking, this offers improved internal logistics as well as high density storage.



FOR MORE INFORMATION CONTACT YOUR LOCAL  
DEXION DISTRIBUTOR

## P90 Push-Back Racking

- gravity ensures access

- ✓ High density storage up to 6 pallets in depth
- ✓ Ideal for LIFO operations
- ✓ Can store pallets on either short or long side
- ✓ Loading and unloading of pallets on the same side of the racking
- ✓ Can be operated by reach truck or counter-balance forklift truck

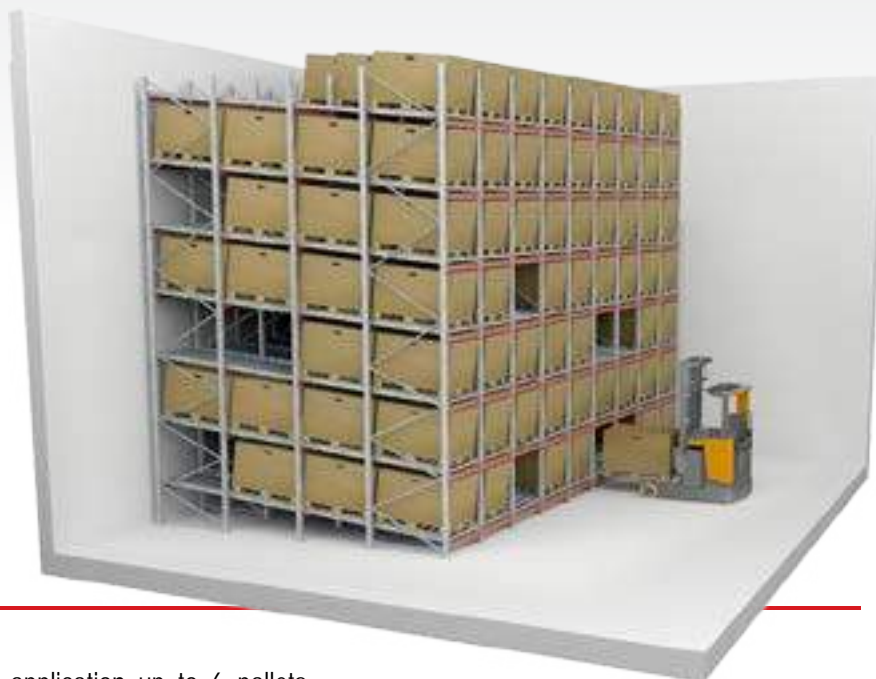

Push-Back Racking is a high density application up to 6 pallets in depth where pallets are delivered and picked at the front of the racking. Gravity transports the next pallet, to be picked, to the front of the racking.





# P90 Carton Flow

## - efficient and ergonomic low level picking

- ✓ Allows efficient picking of small goods at low levels
- ✓ Can be used with a variety of carton sizes
- ✓ Supports FIFO operations
- ✓ Can be used with both cardboard and plastic containers
- ✓ Ideal for retail customers

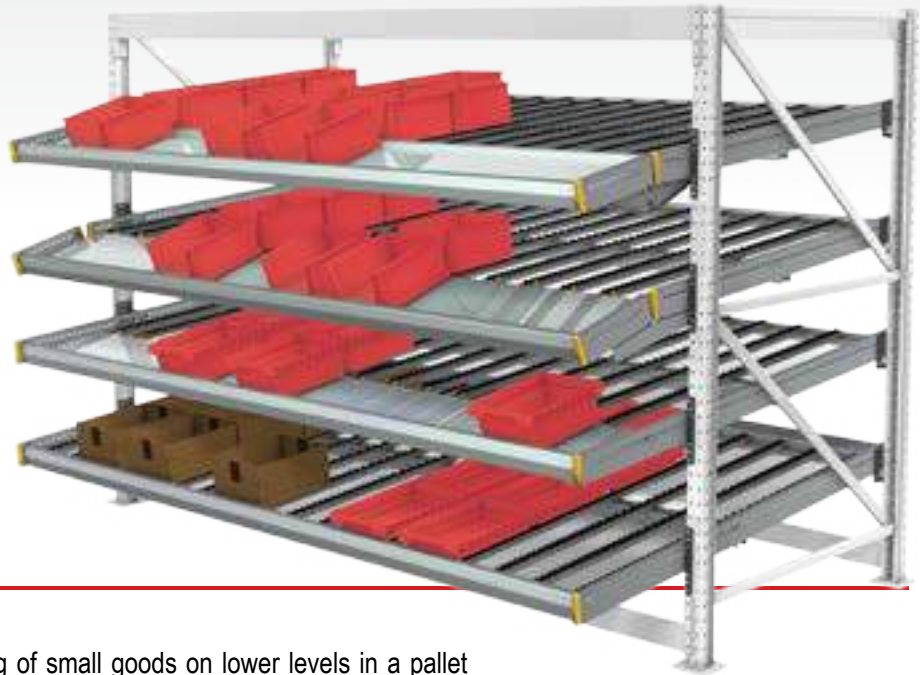

Carton Flow allows efficient picking of small goods on lower levels in a pallet racking system. A picking station is constructed from a rack fitted with sloping roller tracks used to transport the components, loading on one side and unloading on the opposite.





## P90 Accessories

### - Pallet Pull-Out Units

- ✓ Floor or beam mounted Pull-Out Units
- ✓ Universal units that can be mounted onto beams
- ✓ Special dimension pallets can be catered for
- ✓ All loads are based on uniformly distributed pallet loads

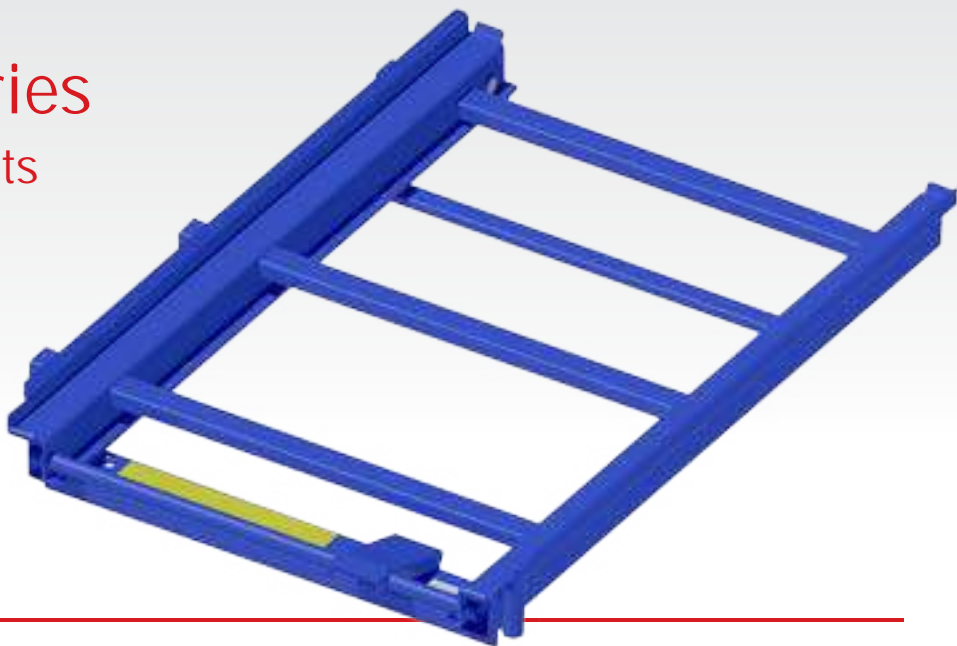

For convenience these universal units can be mounted onto beams or directly to the floor, preventing the operator having to continually bend down. Ideal for lean manufacturing or lineside production environments.

#### Optimised picking

Goods or pallets stored on Pull-Out Units can be picked directly from the racking. Releasing the safety catch and pulling on the unit's handle brings the Pull-Out Unit forward, making the stored goods fully accessible.

Load capacities of up to 1000kg and a pallet pull out distance of between 55% and 100% are possible depending upon the exact specification of the unit.

#### Options available:

- Floor or beam mounted
- Euro or CHEP pallets in both orientations
- Bases for pallets or loose boxes
- Custom designs on request
- Finished in blue RAL 5010 as standard, other colours available on request.



# P90 Accessories

## - Dividers



**Divider Bars** - Used to segregate long goods when stored vertically. Allows fast and direct access.



**Vertical Loop Divider** - Used to support long products which store vertically. Allows fast and direct access.

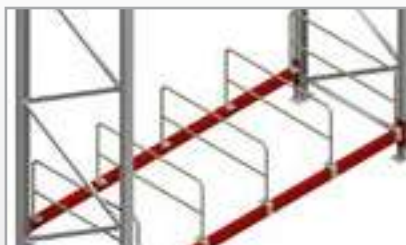

**Horizontal Standing Divider** - Designed for the safe vertical storage of long flat goods. Allows for fast and direct access.



**Horizontal Hanging Divider** - Suspended below front and back beams to store vertical goods. Allows easy access.



## P90 Accessories

### - shelf options



**Chipboard** - Placed between two P90 beams, a chipboard shelf allows a lower beam level to be used as a manual picking shelf.



**Timber Decking** - Fixed wooden plank shelving available open or closed, rough or planed depending on use.



**Mesh Grating** - A strong mesh shelf ideal for storing liquids allowing spills to pass through the shelf to be caught in a drip tray.



**Fork Spacer** - Allows forks to pass under the load when not on a pallet.



**Coil/Drum Cradle** - Full support front to back for cable reels and large drums or canisters.



**Drum Holder** - Placed on the racking beams to allow the storage of barrels or cable reels to prevent them rolling. (Options available: • 900mm long • 1100mm long)



**Pallet Support Bars** - Placed in pairs on racking beams to allow storage of undersized pallets. (Options available: • 900mm long • 1100mm long)



**Half Pallet Support** - Placed on the racking beams to allow storage of undersized pallets. (Options available: • 900mm long • 1100mm long)



**Vertical & Horizontal Pallet Stops** - A useful safety feature which prevents pallets from falling from the back of the rack.

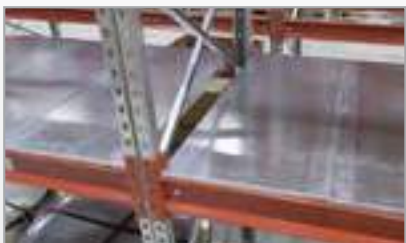

**Steel Shelf Panels**  
(Options available: • 900W x 455W mm (140kg UDL per panel) • 900W x 530W mm (140kg UDL per panel) • 1100W x 455W mm (140kg UDL per panel) • 1100W x 530W mm (140kg UDL per panel))

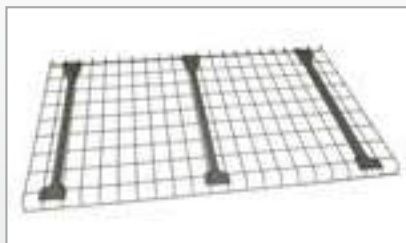

**Wire Mesh Shelving** - Placed on the beams to support undersized pallets or boxes. Often used in warehouses with a sprinkler system to allow flow of water in the event of a fire. (Options available: • 900W x 864W mm (1089kg UDL) • 900W x 1320W mm (1134kg UDL) • 1100W x 864W mm (1134kg UDL) • 1100W x 1320W mm (1000kg UDL))

# P90 Accessories

## - Rack Protection



**Contact us for other sizes**



**Frame Protector Kit** - Up to 400mm high with a solid panel, available in a variety of lengths to suit your frame size. (Options available:  
 • 500 x 900 • 500 x 1100 • 500 x 2000  
 • 500 x 2400)



**E-Rail Barriers** - Designed as collision and impact protection and made from 3mm thick material. (Options available: • 400 x 900  
 • 400 x 1100 • 400 x 2000 • 400 x 2400)



**Tubular Barriers** - These tubular barriers are 50mm high and made from tough steel, are built to withstand the challenges of everyday activities. (Options available: • 500 x 900 • 500 x 1100  
 • 500 x 2000 • 500 x 2400)



**Metal Safety Bollard** - Available in either painted or galvanised finish they offer sturdy protection for vulnerable areas such as doorways. (Options available: • 850 x 168 • 1000 x 168  
 • 1200 x 168)



**C-Rail Barriers** - Designed to protect end of racks as well as pedestrian walkways and made from 5mm thick material to offer sturdy protection. (Options available - Width: 460mm or 760mm  
 Depth options: • 900 • 1100 • 2000 • 2400)



**Anti Collapse Mesh** - prevents any risk of spillage from pallets, offering protection for a variety of scenarios.

FOR MORE INFORMATION CONTACT YOUR LOCAL  
 DEXION DISTRIBUTOR



## P90 Accessories

### - Column Guards



**Metal Column Guard** - Protects pallet racking uprights from low level fork and truck impact. Available 400mm high to meet FEM regulations.



**Metal Corner Column Guard** - Protects pallet racking uprights from low level fork and truck impact. Available 400mm high to meet FEM regulations. Ideal corner protection for the pallet racking uprights.



**Upright Column Guard** - Bolted to the front of the racking upright, the metal guard offers protection with shock absorbing foam inside.



**Protect-It Plastic Guard** - Absorbs heavy impacts, simple to attach allows for regular inspection and costs effective to change when damaged.



**Sacrificial Legs (incl. upright section)** - A non-load bearing, removable section of upright, replaceable if damaged, without the need to unload a complete bay.



**Shock Absorbing Guard** - Specifically designed for protection of uprights placed on corners in a warehouse. A roller at the base helps deflect impacts.

# Light Duty Cantilever Racking

- ✓ Easy to assemble with a quality **galvanised finish**
- ✓ Arms adjustable on 100mm pitch
- ✓ Ideal for storing long, light-weight lengths
- ✓ Can take loads up to 400kg per arm\*
- ✓ Available in both single and double sided configurations
- ✓ Can be extended with additional uprights

Whether you need to store long lengths of timber, plastic pipes, mouldings or other light-weight long goods horizontally and safely, Dexion's Light Duty Cantilever Racking system is ideal. Made from sturdy galvanised steel, the Light Duty Cantilever Racking is offered as either single sided racks to go against a wall or as a double sided rack for access from both sides. This racking is fully modular, enabling additional sections to be added.

**Height:** 2000mm or 2500mm

**Arm length:** 300 / 400 / 500 / 600mm

**Distance between uprights:** 1000 / 1250 / 1500 / 1750 / 2000mm

\*The loads are calculated in accordance with the relevant FEM standard and EN 1993-1-3, design of steel structure.

If you predict higher loads on the racking, please use our Heavy Duty Cantilever System.



Arm height adjustment in 100mm increments.



Safety end stoppers are available as an extra option.



Braced for maximum rigidity in widths of 1000 / 1250 / 1500 / 1750 / 2000mm.



The racking is fixed to the floor using M10 x 90mm anchor bolts.



**Galvanised finish**



**Contact us for details**

FOR MORE INFORMATION CONTACT YOUR LOCAL  
DEXION DISTRIBUTOR



# Heavy Duty Cantilever Racking

- ✓ Ideal for storage of long lengths and heavy loads\*
- ✓ Utilises the full height of the warehouse when required
- ✓ External paint or hot-dip galvanised finish for outdoor installation
- ✓ Available in single or double sided configurations
- ✓ A range of arm stops and label holders available

The load capacity is dependent on design and customer requirements.

Contact us to discuss your design.

\*The loads are calculated in accordance with the relevant FEM standard and EN 1993-1-3 design of steel structure.



Cantilever racking allows you to use your warehouse space more efficiently – space is not wasted as horizontally stored goods can be stacked above each other while still allowing access to each item or bundle.

Each system is fully customised to suit your specific requirements. This bespoke manufactured solution is so versatile that different component combinations can be used in various situations. The cantilever arms can be easily adjusted in height. The system comes in blue as standard, but other colours are available on request.

For outside installations, external paint is available or a hot-dip galvanised can be provided where a corrosive environment is present.



 **Contact us for details**

# Mezzanine Floors

- ✓ Ideal solution when floor space is limited
- ✓ Can be used in conjunction with Dexion racking or shelving to maximise storage
- ✓ Hand rail and Pallet Gates available to offer protection
- ✓ Timber or steel grating floor finishes available to suit your needs
- ✓ Can be fitted with lighting and sprinklers where required

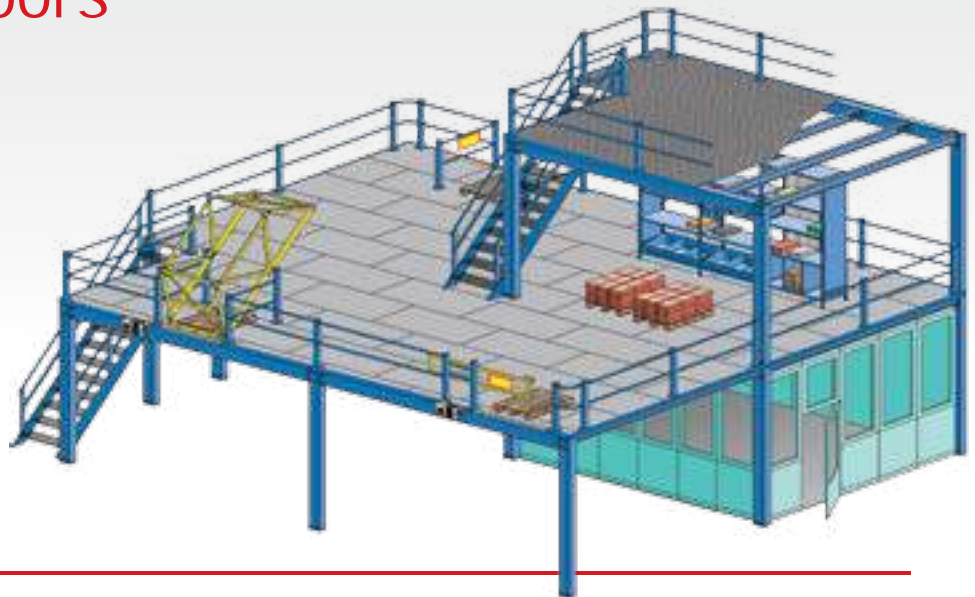

• Pallet Gates



• Hand Rails



• Stairs



 **Contact us for details**

FOR MORE INFORMATION CONTACT YOUR LOCAL  
DEXION DISTRIBUTOR



# Partitioning Systems

- ✓ Ideal for both offices and warehouses
- ✓ A range of finishes available
- ✓ Can be fitted at ground level or on mezzanine floors
- ✓ High quality for offices or robust finishes for warehouses
- ✓ Designed to meet your needs

A poor working environment in a company can result in reduced productivity. Such environments could be high noise levels, dirt or dust. These are problems which can be solved by simply creating a partition between the unacceptable working environment and the employees.



 **Contact us for details**

# Storage Machines

## Tornado

- ✓ Ergonomic - brings the tray to operator's optimum height.
- ✓ Saves up to 70% floor space
- ✓ Up to 65% reduction in picking times
- ✓ **Rapid and efficient** support with Dexion remote assistance via internet
- ✓ Suitable for storage of products of various sizes or weights



## Paternoster

- ✓ Semi-automated shelf carousel
- ✓ Machine heights up to 15 metres
- ✓ Reduces picking errors by up to two thirds
- ✓ Particularly suited to batch picking, average 15 seconds per row pick time
- ✓ Safe and ergonomic work environment with goods presented at optimum height



Dexion's Tornado machine facilitates modern picking techniques when storing various sized products. The Tornado is a swift, energy saving and quiet automated storage system. Utilising the lift principle for storage, it brings the required tray of products to the operator. Each machine is tailored to individual storage requirements.

The Dexion Paternoster is a safe and secure storage system that utilises the goods-to-person principle, by reducing the walking distance of a picker. Introducing batch picking can reduce these times further. This carousel system saves floor space and keeps products away from dust and light.

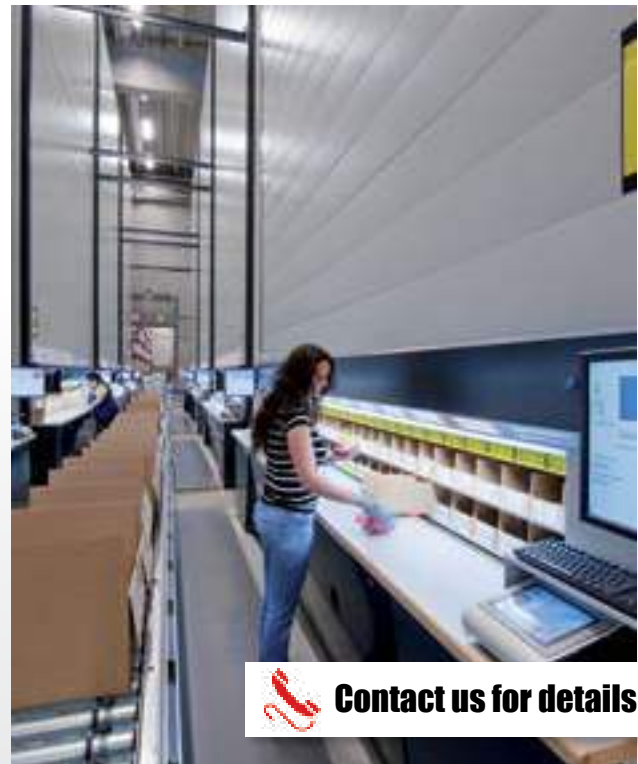

**Contact us for details**

FOR MORE INFORMATION CONTACT YOUR LOCAL DEXION DISTRIBUTOR



# Rack Inspections



## Keep your warehouse safe

- By spotting the details that cause damage early

Accidents happen in any warehouse, but regular inspections could minimize the number and effect of them. Dexion's rack inspectors offer a convenient, comprehensive and cost effective way to keep your warehouse safe.

Small changes throughout the year – caused by moving of goods, fitting and refitting of the racks and general knocks through the daily use – can in the end seriously change the capacity of the racks. This can lead to incidents in a warehouse, potentially causing damage to both man and material. The challenge is to spot the changes early enough to avoid additional future costs, which requires the experience of a trained expert who knows what to look for.

Dexion's rack inspectors are fully certified, and highly experienced to conduct yearly inspections to ensure your facilities are kept safe. Following every inspection a detailed report is provided, offering advice and indicating areas that require immediate action or future attention by using a simple traffic light indicator. Each visit is certified and documentation provided that can be clearly displayed on the racks to confirm our inspection.

Our inspections strictly comply with all government guidelines and legislation and any rectification work is fully guaranteed.

Keep your warehouse safe. Let us identify the early signs before it's too late.

### The benefits of a Dexion rack inspection:

- Comprehensive professional inspection
- Certified and experienced inspectors
- Detailed inspection report
- Extending life span of facilities
- No interruption to operations
- Prevention of damage to people or goods
- Early risk identification minimises future repair costs
- Repair work can be completed quickly and professionally



Your Dexion Distributor is:



**STORAGE SYSTEMS**

**Storage Systems Ltd**  
Malahide Road Ind. Park  
Coolock  
Dublin 17

Tel: 01 871 1400  
Email: [sales@storagesystems.ie](mailto:sales@storagesystems.ie)  
Web: [www.dexion.ie](http://www.dexion.ie)